

伊斯卡深钻 GPS

深钻硬质合金导板

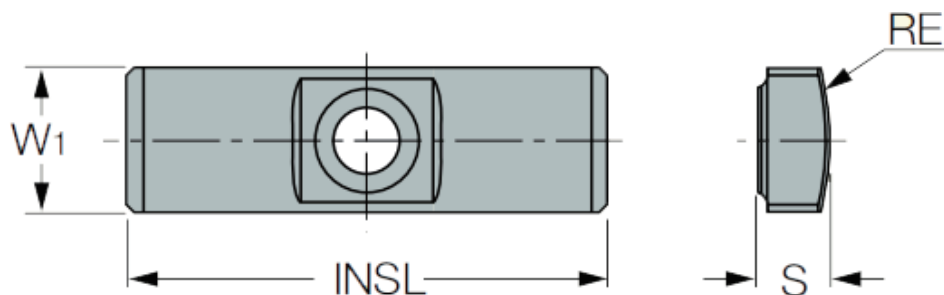

样图	直径范围	刀片型号	W1	RE	INDL	S	扳手	螺丝	牌号
		GPS-04-16-055	4.00	5.50	16.0	2.00			
	14.00-15.99	GPS-05-18-060	5.00	6.00	18.0	2.50			
	16.00-18.00	GPS-05-20-075	6.00	7.50	20.0	3.00			
	18.01-21.00	GPS-06-20-085	6.00	8.50	20.0	3.00			
	21.01-28.00	GPS-06-20-100	6.00	10.0	20.0	3.00			
	25.01-28.00	GPS-06-20-120	6.00	12.0	20.0	3.00	T-7	SR34-508	
	30.00-39.00	GPS-07-20-120	7.00	12.0	20.0	3.50			
	39.01-45.00	GPS-08-25-155	8.00	15.5	25.0	4.50			
	45.01-57.00	GPS-10-30-200	10.0	20.0	30.0	4.50			
			GPS-10-35-200	10.0	20.0	35.0	6.00		
57.01-65.00	GPS-12-35-250	12.0	25.0	35.0	5.50				
		GPS-14-40-250	14.0	25.0	40.0	7.50			
		GPS-18-40-300	18.0	30.0	40.0	9.00			

伊斯卡深钻 NPMT/NPHT

NPMT-L2/R2 NPMT-R1/2-DT

NewCermets
新陶新材

NPMT

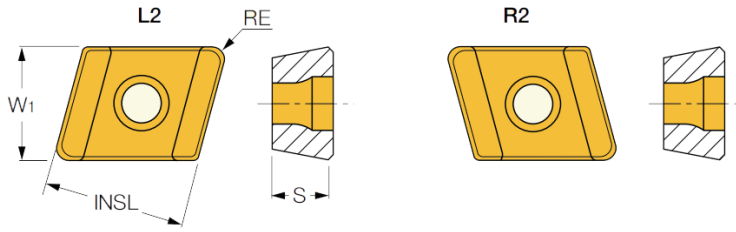

NPHT

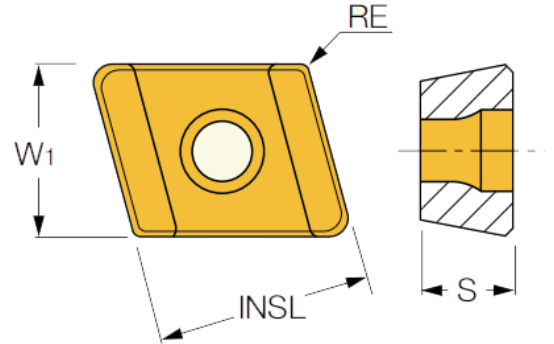

样图	直径范围	刀片型号	W1	RE	INDL	S	扳手	螺丝	牌号	
	25.00-28.00 28.01-29.99	NPHT 06003RG	6.0	0.30	8.0	3.0				
	30.22-35.00 35.01-38.00	NPHT 07504RG	7.5	0.40	10.0	4.0				
	38.01-39.00 39.01-41.00 41.01-44.00 44.01-45.00 45.01-47.00	NPHT 09004RG	9.0	0.40	10.0	4.0				
	47.01-51.00 51.01-54.00 54.01-57.00 57.01-60.00	NPHT 11004RG	11.0	0.40	10.0	4.0				
	60.01-64.00 64.01-65.00	NPHT 13004RG	13.0	0.40	10.0	4.0				
样图	直径范围	刀片型号	W1	S	INSL	L	RE	扳手	螺丝	牌号
	25.00-28.00 28.01-29.99	NPMT 07504R2-DT	7.50	4.00	10.00	7.20	0.40			
		NPMT 09504R2-DT	9.50	4.00	10.00	9.20	0.40			
	30.00-35.00 35.01-38.00 38.01-39.00 39.01-41.00	NPMT 05503R/L2	5.50	3.00	8.00	-	0.30			
		NPMT 06504R/L2	6.50	4.00	10.00	-	0.40			
	41.01-44.00 44.01-45.00 45.01-47.00 47.01-51.00	NPMT 0804R/L2	8.00	4.00	10.00	-	0.80			
		NPMT 09504R/L2	9.50	4.00	10.00	-	0.80			
	64.01-65.00	NPMT 12504R/L2	12.50	4.00	10.00	-	0.40			

钻头直径	周边刀片			中间刀片			中心刀片			导向块		
	镶嵌	螺丝	扳手	镶嵌	螺丝	扳手	镶嵌	螺丝	扳手	镶嵌	螺丝	扳手
												
25.00-28.00	NPHT 06003RG	SR 11201753-2	T-7/5	NPMT 05503R2	SR 11201753-2	T-7/5	NPMT 05503L2	SR 11201753-2	T-7/5	GPS06	SR 11201753-1	T-7/5
28.01-29.99	NPHT 06003RG	SR 11201753-2	T-7/5	NPMT 05503R2	SR 11201753-2	T-7/5	NPMT 06504L2	SR 11201753-2	T-8/5	GPS06	SR 11201753-1	T-7/5
30.00-35.00	NPHT 07504RG	SR 11201753-3	T-8/5	NPMT 06504R2	SR 11201753-3	T-8/5	NPMT 06504L2	SR 11201753-3	T-8/5	GPS07	SR 11201753-4	T-9/5
35.01-38.00	NPHT 07504RG	SR 11201753-3	T-8/5	NPMT 06504R2	SR 11201753-3	T-8/5	NPMT 0804L2	SR 11201753-3	T-8/5	GPS07	SR 11201753-4	T-9/5
38.01-39.00	NPHT 09004RG	SR 11201753-3	T-8/5	NPMT 06504R2	SR 11201753-3	T-8/5	NPMT 0804L2	SR 11201753-3	T-8/5	GPS07	SR 11201753-4	T-9/5
39.01-41.00	NPHT 09004RG	SR 11201753-3	T-8/5	NPMT 06504R2	SR 11201753-3	T-8/5	NPMT 0804L2	SR 11201753-3	T-8/5	GPS08	SR 11201753-4	T-9/5
41.01-44.00	NPHT 09004RG	SR 11201753-3	T-8/5	NPMT 0804R2	SR 11201753-3	T-8/5	NPMT 0804L2	SR 11201753-3	T-8/5	GPS08	SR 11201753-4	T-9/5
44.01-45.00	NPHT 09004RG	SR 11201753-3	T-8/5	NPMT 0804R2	SR 11201753-3	T-8/5	NPMT 09504L2	SR 11201753-3	T-8/5	GPS08	SR 11201753-4	T-9/5
45.01-47.00	NPHT 09004RG	SR 11201753-3	T-8/5	NPMT 0804R2	SR 11201753-3	T-8/5	NPMT 09504L2	SR 11201753-3	T-8/5	GPS10	SR 11201753-6	T-15/5
47.01-51.00	NPHT 11004RG	SR 11201753-3	T-8/5	NPMT 0804R2	SR 11201753-3	T-8/5	NPMT 09504L2	SR 11201753-3	T-8/5	GPS10	SR 11201753-6	T-15/5
51.01-54.00	NPHT 11004RG	SR 11201753-3	T-8/5	NPMT 09504R2	SR 11201753-3	T-8/5	NPMT 09504L2	SR 11201753-3	T-8/5	GPS10	SR 11201753-6	T-15/5
54.01-57.00	NPHT 11004RG	SR 11201753-3	T-8/5	NPMT 09504R2	SR 11201753-3	T-8/5	NPMT 12504L2	SR 11201753-3	T-8/5	GPS10	SR 11201753-6	T-15/5
57.01-60.00	NPHT 11004RG	SR 11201753-3	T-8/5	NPMT 09504R2	SR 11201753-3	T-8/5	NPMT 12504L2	SR 11201753-3	T-8/5	GPS12	SR 11201753-6	T-15/5
60.01-64.00	NPHT 13004RG	SR 11201753-3	T-8/5	NPMT 09504R2	SR 11201753-3	T-8/5	NPMT 12504L2	SR 11201753-3	T-8/5	GPS12	SR 11201753-6	T-15/5
64.01-65.00	NPHT 13004RG	SR 11201753-3	T-8/5	NPMT 12504R2	SR 11201753-3	T-8/5	NPMT 12504L2	SR 11201753-3	T-8/5	GPS12	SR 11201753-6	T-15/5

伊斯卡深钻 TPMX

钻头嵌件

Newcermets
新陶新材

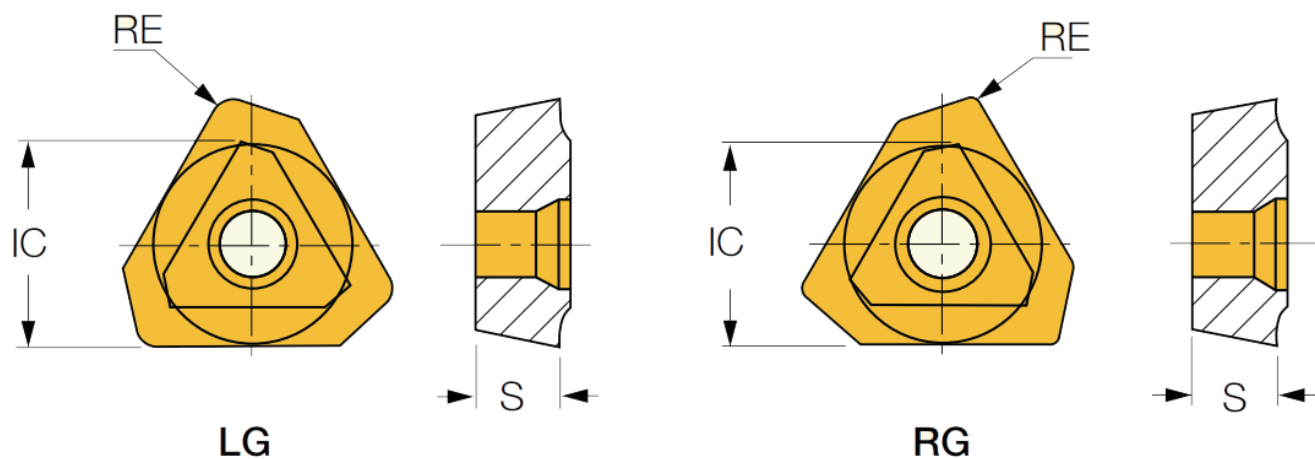

样图	直径范围	刀片型号	IC	S	RE	扳手	螺丝	牌号
		TPMX 1403R/LG	8.45	3.50	0.80			
		TPMX 1403R-DT	8.45	3.50	0.80			
		TPMX 1403RB	8.45	3.50	0.40			
		TPMX 1704R-DT	10.30	4.00	0.80			
		TPMX 1704RB	10.30	4.00	0.40			
		TPMX 1704R/LBG	10.30	4.00	0.80			
		TPMX 1704R/LG	10.30	4.00	0.80			
		TPMX 2405R-DT	14.20	5.50	1.20			
		TPMX 2405RB	14.20	5.50	0.40			
		TPMX 2405R-LBG	14.20	5.50	1.20			
		TPMX 2405R/LG	14.20	5.50	1.20			
		TPMX 2807R-DT	17.00	7.50	1.60			
		TPMX 2807RB	17.00	7.50	0.80			
		TPMX 2807R/LBG	17.00	7.50	1.60			
TPMX 2807R/LG	17.00	7.50	1.60					

伊斯卡深钻 TOGT

3片深钻刀片分裂切削刃 正耙式断屑槽和修光刃

NewCermets
新陶新材

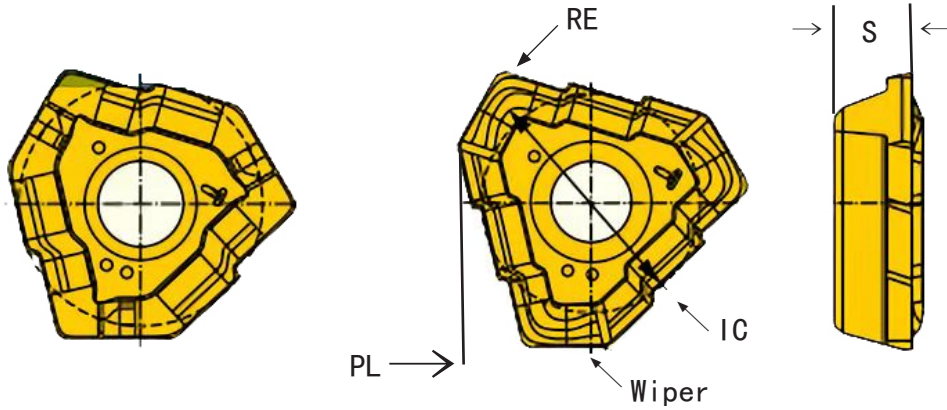

样图	直径范围	刀片型号	di	R	E _{h1}	S	Fig	扳手	螺丝	牌号
	14.00-15.99	TOGT 070304-DT	7.69	0.40	1.95	2.30	1	T-8	SR-14-560/S	
	16.00-18.00	TOGT 080305-DT	8.55	0.50	2.20	0.80	1	T-8	SR-14-560/S	
	18.01-20.00	TOGT 090305-DT	8.32	0.50	3.00	3.00	2	T-8	SR-14-560/S	
	20.01-21.99 21.00-21.99	TOGT 100305-DT	9.23	0.50	3.20	3.30	2	T-8	SR-34-506	
	22.00-25.00	TOGT 110405-DT	10.40	0.50	3.40	3.80	2	T-15	SR-14-571/S	
	25.01-28.00	TOGT 120405-DT	11.59	0.50	3.60	4.30	2	T-15	SR-14-506	

深孔钻削

用于CoroDrill 800.24和800.20整体钻头的刀片

中心刀片

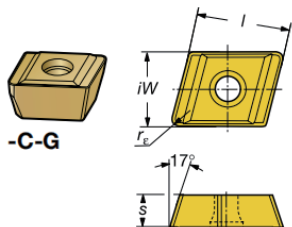

中间刀片

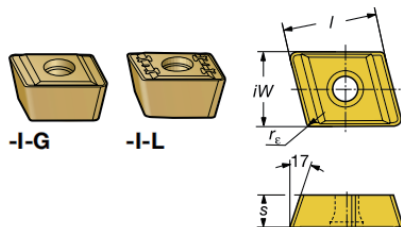

周边刀片

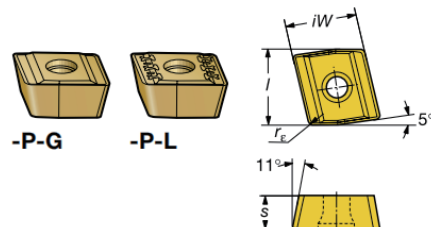

样图	直径范围	刀片型号	尺寸				扳手	螺丝	牌号
			iW	l	S	R			
		中心刀片							
	25,00-28,70	800-05 03 08M-C-G	5,56	9,87	3,18	0,8			
	28,71-33,99	800-06 T3 08M-C-G	6,35	9,87	3,97	0,8			
	34,00-43,00	800-08 T3 08M-C-G	7,94	9,87	3,97	0,8			
	43,01-47,00	800-10 T3 08M-C-G	9,53	9,87	3,97	0,8			
	47,01-49,99	800-12 T3 08M-C-G	12,70	9,87	3,97	0,8			
		中间刀片							
	25,00-31,00	800-05 03 08M-I-G	5,56	9,87	3,18	0,8			
	25,00-31,00	800-05 03 08M-I-L	5,56	9,87	3,18	0,8			
	31,01-34,99	800-06-T3 08M-I-G	6,35	9,87	3,97	0,8			
	31,01-34,99	800-06 T3 08M-I-L	6,35	9,87	3,97	0,8			
	35,00-54,99	800-08-T3 08M-I-G	7,94	9,87	3,97	0,8			
	35,00-54,99	800-08-T3 08M-I-L	7,94	9,87	3,97	0,8			
	55,00-65,00	800-12-T3 08M-I-G	12,70	9,87	3,97	0,8			
55,00-65,00	800-12-T3 08M-I-L	12,70	9,87	3,97	0,8				
		周边刀片							
	25,00-31,00	800-06 03 08H-P-G	8,00	6,50	3,18	0,8			
	25,00-31,00	800-06 03 08H-P-L	8,00	6,50	3,18	0,8			
	31,01-38,99	800-08 T3 08H-P-G	9,00	8,50	3,97	0,8			
	31,01-38,99	800-08 T3 08H-P-L	9,00	8,50	3,97	0,8			
	39,00-49,99	800-09 T3 08H-P-G	9,00	9,68	3,97	0,8			
	39,00-49,99	800-09 T3 08H-P-L	9,00	9,68	3,97	0,8			
	50,00-65,00	800-11 T3 08H-P-G	9,00	12,75	3,97	0,8			
50,00-65,00	800-11 T3 08H-P-L	9,00	12,75	3,97	0,8				

深孔钻削

T-MAX 424.10 整体钻头刀片

NewCermets
新陶新材

中心和中间刀片



TPMT-22
TPMT-23

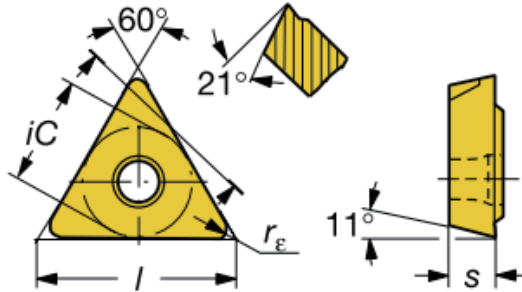

周边刀片



R424.9-22
R424.9-23

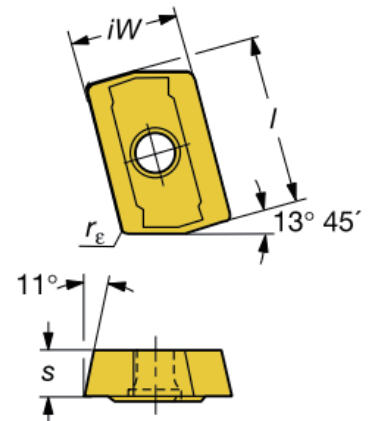

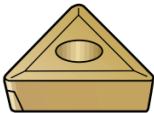
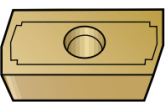
样图	直径范围	刀片型号	尺寸					扳手	螺丝	牌号
			ic	iw	l	S	R ε			
		中心和中间刀片								
		TPMT 16 T3 12R-22	9,525	-	16,5	3,97	1,2			
		16 T3 12TR-23	9,525	-	16,5	3,97	1,2			
		TPMT 22 06 12R-22	12,7	-	22,0	6,35	1,2			
		22 06 12TR-23	12,7	-	22,0	6,35	1,2			
		周边刀片								
		R424.9- 13 T3 08-22	-	10,0	14,7	3,97	0,8			
		13 T3 08-23	-	10,0	14,7	3,97	0,8			
		R424.9- 18 06 08-22	-	11,5	20,6	6,35	0,8			
		18 06 08-23	-	11,5	20,6	6,35	0,8			

深孔钻削

用于CoroDrill800 整体钻头的支撑板

NewCermets
新陶新材

支撑板 PM1

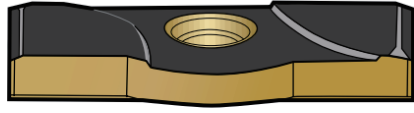

支撑板 P1 和 M1

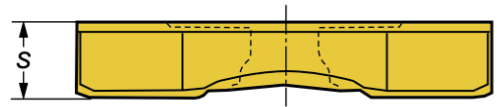
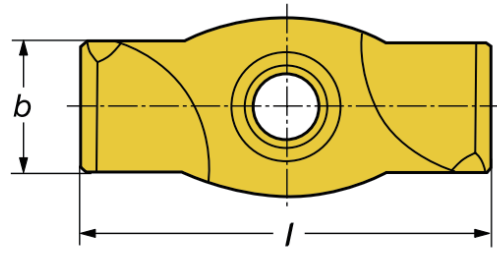
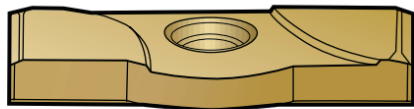

	直径范围	型号	尺寸			扳手	螺丝	牌号
			b	l	s			
	25,00-31,00	800-06A	6	18	3,0			
	31,01-39,60	800-07A	7	20	3,5			
	39,61-47,00	800-08A	8	25	4,5			
	47,01-54,99	800-10A	10	30	4,5			
	55,00-65,00	800-12A	12	35	5,5			